

SOLENOID VALVE - ORDERING CODE

AC

REF. CAT. NO.	TYPE OF VALVE	PORT SIZE			NW	Operating pressure range (bar)	ORDERING NO. WITH COIL VOLTAGE OF (all coils are provided with DIN connector type socket S1)				Remarks	
		IN	OUT	EXH			AC					
							220 V	110 V	48 V	24 V		
Direct acting valves												
J001 - 04	2/2 NC	G1/4	G1/4	NIL	3.0	0 - 10	E12614A	E12614B	E12614D	E12614G		
J013 - 02	2/2 NC	G1/4	G1/4	NIL	2.5	0 - 7	E12613A	E12613B	E12613D	E12613G		
J013 - 02	2/2 NC	G1/4	G1/4	NIL	2	0 - 10	E12612A	E12612B	E12612D	E12612G		
J013 - 02	2/2 NC	G1/4	G1/4	NIL	1.2	0 - 20	E12611A	E12611B	E12611D	E12611G		
J002 - 04	3/2 NO	G1/8	G1/4	G1/4	2.5	0 - 7	E13613A	E13613B	E13613D	E13613G		
J002 - 04	3/2 NO	G1/8	G1/4	G1/4	2.0	0 - 10	E13612A	E13612B	E13612D	E13612G		
J002 - 04	3/2 NO	G1/8	G1/4	G1/4	1.2	0 - 20	E13611A	E13611B	E13611D	E13611G		
J003 - 04	3/2 NC	G1/4	G1/4	G1/8	2.5	0 - 7	E14613A	E14613B	E14613D	E14613G		
J003 - 04	3/2 NC	G1/4	G1/4	G1/8	2.0	0 - 10	E14612A	E14612B	E14612D	E14612G		
J003 - 04	3/2 NC	G1/4	G1/4	G1/8	1.2	0 - 20	E14611A	E14611B	E14611D	E14611G		
J004 - 04	3/2 Gang mounting NC	NIL	NIL	G1/8	2	0 - 10	E24002A	E24002B	E24002D	E24002G		Screw type manual adjuster
							E24002A - K	E24002B - K	E24002D - K	E24002G - K		Knob type manual adjuster
Pilot operated valves												
J005 - 05	3/2 Single pilot NO	G1/4	G1/4	G1/4	6	2 - 10	EL13615A	EL13615B	EL13615D	EL13615G	Screw type manual adjuster	
							EL13615A - K	EL13615B - K	EL13615D - K	EL13615G - K	Knob type manual adjuster	
J006 - 05	3/2 Single pilot NC	G1/4	G1/4	G1/4	6	2 - 10	EL14615A	EL14615B	EL14615D	EL14615G	Screw type manual adjuster	
							EL14615A - K	EL14615B - K	EL14615D - K	EL14615G - K	Knob type manual adjuster	
J007 - 05	3/2 Single pilot NO	G1/2	G1/2	G1/2	12	2 - 10	EL13637A	EL13637B	EL13637D	EL13637G	Screw type manual adjuster	
							EL13637A - K	EL13637B - K	EL13637D - K	EL13637G - K	Knob type manual adjuster	
J008 - 05	3/2 Single pilot NC	G1/2	G1/2	G1/2	12	2 - 10	EL14637A	EL14637B	EL14637D	EL14637G	Screw type manual adjuster	
							EL14637A - K	EL14637B - K	EL14637D - K	EL14637G - K	Knob type manual adjuster	
J009 - 05	5/2 Single pilot	G1/4	G1/4	G1/4	6	2 - 10	EL15615A	EL15615B	EL15615D	EL15615G	Screw type manual adjuster	
							EL15615A - K	EL15615B - K	EL15615D - K	EL15615G - K	Knob type manual adjuster	
J010 - 05	5/2 Single pilot	G1/2	G1/2	G1/2	12	2 - 10	EL15637A	EL15637B	EL15637D	EL15637G	Screw type manual adjuster	
							EL15637A - K	EL15637B - K	EL15637D - K	EL15637G - K	Knob type manual adjuster	
J011 - 05	5/2 Double pilot	G1/4	G1/4	G1/4	6	2 - 10	EL25615A	EL25615B	EL25615D	EL25615G	Screw type manual adjuster	
							EL25615A - K	EL25615B - K	EL25615D - K	EL25615G - K	Knob type manual adjuster	
J012 - 05	5/2 Double pilot	G1/2	G1/2	G1/2	12	2 - 10	EL25637A	EL25637B	EL25637D	EL25637G	Screw type manual adjuster	
							EL25637A - K	EL25637B - K	EL25637D - K	EL25637G - K	Knob type manual adjuster	

DC

REF. CAT. NO.	TYPE OF VALVE	PORT SIZE			NW	Operating pressure range (bar)	ORDERING NO. WITH COIL VOLTAGE OF (all coils are provided with DIN connector type socket S1)				Remarks	
		IN	OUT	EXH			DC					
							110 V	48 V	24 V	12 V		
Direct acting valves												
J001 - 04	2/2 NC	G1/4	G1/4	NIL	3.0	0 - 10	NIL	NIL	NIL	NIL		
J013 - 02	2/2 NC	G1/4	G1/4	NIL	2.5	0 - 7	E12613Q	E12613S	E12613W	E12613R		
J013 - 02	2/2 NC	G1/4	G1/4	NIL	2	0 - 10	E12612Q	E12612S	E12612W	E12612R		
J013 - 02	2/2 NC	G1/4	G1/4	NIL	1.2	0 - 20	E12611Q	E12611S	E12611W	E12611R		
J002 - 04	3/2 NO	G1/8	G1/4	G1/4	2.5	0 - 7	-	-	-	-		
J002 - 04	3/2 NO	G1/8	G1/4	G1/4	2.0	0 - 10	-	-	-	-		
J002 - 04	3/2 NO	G1/8	G1/4	G1/4	1.2	0 - 20	-	-	-	-		
J003 - 04	3/2 NC	G1/4	G1/4	G1/8	2.5	0 - 7	E14613Q	E14613S	E14613W	E14613R		
J003 - 04	3/2 NC	G1/4	G1/4	G1/8	2.0	0 - 10	E14612Q	E14612S	E14612W	E14612R		
J003 - 04	3/2 NC	G1/4	G1/4	G1/8	1.2	0 - 20	E14611Q	E14611S	E14611W	E14611R		
J004 - 04	3/2 Gang mounting NC	NIL	NIL	G1/8	2	0 - 10	E24002Q	E24002S	E24002W	E24002R		Screw type manual adjuster
							E24002Q - K	E24002S - K	E24002W - K	E24002R - K		Knob type manual adjuster
Pilot operated valves												
J005 - 05	3/2 Single pilot NO	G1/4	G1/4	G1/4	6	2 - 10	EL13615Q	EL13615S	EL13615W	EL13615R	Screw type manual adjuster	
							EL13615Q - K	EL13615S - K	EL13615W - K	EL13615R - K	Knob type manual adjuster	
J006 - 05	3/2 Single pilot NC	G1/4	G1/4	G1/4	6	2 - 10	EL14615Q	EL14615S	EL14615W	EL14615R	Screw type manual adjuster	
							EL14615Q - K	EL14615S - K	EL14615W - K	EL14615R - K	Knob type manual adjuster	
J007 - 05	3/2 Single pilot NO	G1/2	G1/2	G1/2	12	2 - 10	EL13637Q	EL13637S	EL13637W	EL13637R	Screw type manual adjuster	
							EL13637Q - K	EL13637S - K	EL13637W - K	EL13637R - K	Knob type manual adjuster	
J008 - 05	3/2 Single pilot NC	G1/2	G1/2	G1/2	12	2 - 10	EL14637Q	EL14637S	EL14637W	EL14637R	Screw type manual adjuster	
							EL14637Q - K	EL14637S - K	EL14637W - K	EL14637R - K	Knob type manual adjuster	
J009 - 05	5/2 Single pilot	G1/4	G1/4	G1/4	6	2 - 10	EL15615Q	EL15615S	EL15615W	EL15615R	Screw type manual adjuster	
							EL15615Q - K	EL15615S - K	EL15615W - K	EL15615R - K	Knob type manual adjuster	
J010 - 05	5/2 Single pilot	G1/2	G1/2	G1/2	12	2 - 10	EL15637Q	EL15637S	EL15637W	EL15637R	Screw type manual adjuster	
							EL15637Q - K	EL15637S - K	EL15637W - K	EL15637R - K	Knob type manual adjuster	
J011 - 05	5/2 Double pilot	G1/4	G1/4	G1/4	6	2 - 10	EL25615Q	EL25615S	EL25615W	EL25615R	Screw type manual adjuster	
							EL25615Q - K	EL25615S - K	EL25615W - K	EL25615R - K	Knob type manual adjuster	
J012 - 05	5/2 Double pilot	G1/2	G1/2	G1/2	12	2 - 10	EL25637Q	EL25637S	EL25637W	EL25637R	Screw type manual adjuster	
							EL25637Q - K	EL25637S - K	EL25637W - K	EL25637R - K	Knob type manual adjuster	

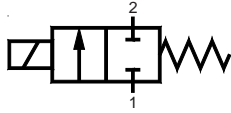

SOLENOID VALVE - G1/4

J Series

Cat No J001 - 04

2 / 2 Direct acting normally closed valve

Features

- ❑ Wide range of coil voltages.
- ❑ Continuous duty cycle.
- ❑ Low temperature of operation
- ❑ Noiseless performance
- ❑ Coil can be rotated by 360°

Technical Specifications

Model #	E12614
Port size	Inlet, Outlet - G1/4
Ambient Temperature	60°C Max.
Medium	Filtered compressed air
Orifice (NW)	3
Operating pressure (bar)	0 - 10 bar
Flow rate (lpm) *	250
Electrical	
Coil width	32 mm
Voltage (V) ± 10%	AC (50 Hz) 24, 48, 110, 220
Power consumption (Watts)	6
Duty cycle	Continuous
Class of insulation	Class F
Type of coil protection	IP65
Materials of construction	Aluminium, Brass, Stainless steel, Nitrile

For ordering refer page no.3.1.1

* at 6 bar inlet, 5 bar outlet , with pressure drop +p = 1 bar

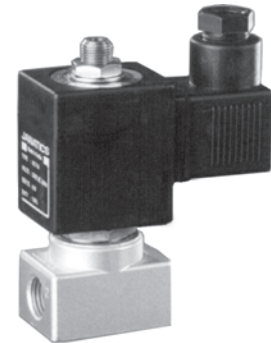

Spare parts list

Ref. No.	Coil (without socket)	Ordering no. for
	Voltage	AC 50Hz
1	220	AC11A
	110	AC11B
	48	AC11D
	24	AC11G
2	Moving core sub assembly complete consists of 1. moving core subassembly 2. main spring	SSA0311

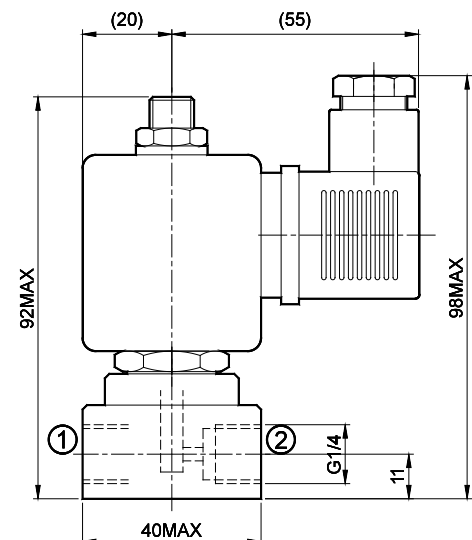
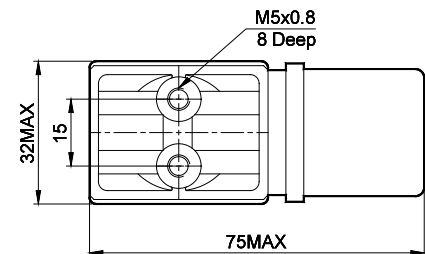
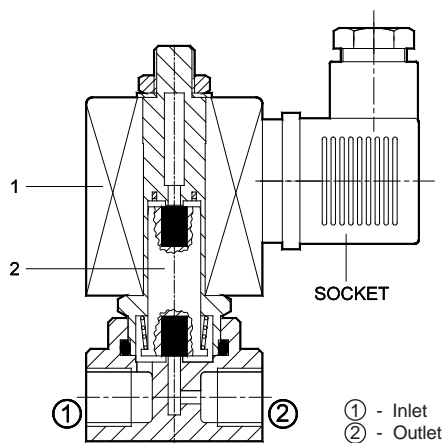

Caution:

A.C coil should not be used on a D.C coil valve, and vice versa.

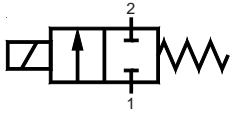

SOLENOID VALVE - G1/4

J Series

Cat No J013 - 02

2 / 2 Direct acting normally closed valve

Features

- Wide range of coil voltages.
- Continuous duty cycle.
- Low temperature of operation
- Noiseless performance
- Coil can be rotated by 360°.



Technical Specifications

Model #	E12613	E12612	E12611
Port size	Inlet, Outlet - G1/4		
Ambient Temperature	60°c Max.		
Medium	Filtered compressed air		
Orifice (NW)	2.5	2	1.2
Operating pressure (bar)	0 - 7	0 - 10	0 - 20
Flow rate (lpm) *	180	140	60
Electrical			
Coil width	32 mm		
Voltage (V) ± 10%	AC (50 Hz)		DC
	24, 48, 110, 220	12	24, 48, 110
Power consumption (Watts)	6	9	8
Duty cycle	Continuous		
Type of coil protection	IP65		
Class of insulation	Class F		
Materials of construction	Aluminium, Brass, Stainless steel, Nitrile		

For ordering refer page no.3.1.1

* at 6 bar inlet, 5 bar outlet , with pressure drop +p = 1 bar

Spare parts list

Ref. No.	Coil (without socket)	Ordering no. for	
		AC 50Hz	DC
1	220	AC11A	- NA -
	110	AC11B	DC12Q
	48	AC11D	DC12S
	24	AC11G	DC12W
	12	- NA -	DC15R
2	Moving core sub assembly complete consists of 1. moving core subassembly 2. main spring	SSA0311	SSA0711

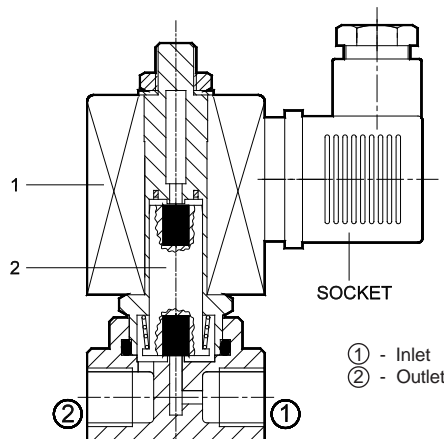
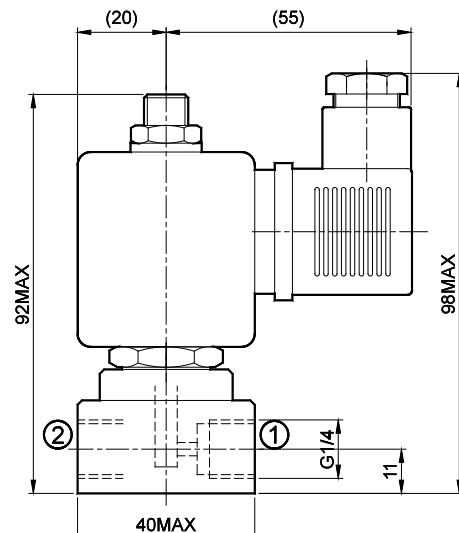
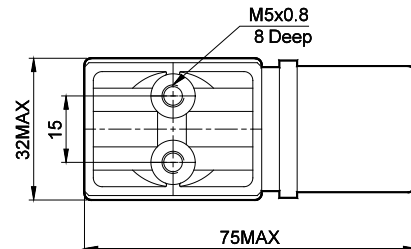

Caution:

A.C coil should not be used on a D.C coil valve, and vice versa.

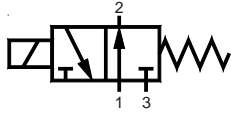

SOLENOID VALVE - G1/4

J Series

Cat No J002 - 04

3 / 2 Direct acting normally open valve

Features

- ❑ Wide range of coil voltages.
- ❑ Continuous duty cycle.
- ❑ Low temperature of operation
- ❑ Noiseless performance
- ❑ Coil can be rotated by 360°.



Technical Specifications

Model #	E13613	E13612	E13611
Port size	Inlet - G1/8, Outlet, Exhaust - G1/4		
Ambient Temperature	60°C Max.		
Medium	Filtered compressed air		
Orifice (NW)	2.5	2	1.2
Operating pressure (bar)	0 - 7	0 - 10	0 - 20
Flow rate (lpm) *	180	140	60
Electrical			
Coil width	32 mm		
Voltage (V) ± 10%	AC (50 Hz) 24, 48, 110, 220		
Power consumption (Watts)	6		
Duty cycle	Continuous		
Type of coil protection	IP65		
Class of insulation	Class F		
Materials of construction	Aluminium, Brass, Stainless steel, Nitrile		

For ordering refer page no.3.1.1

* at 6 bar inlet, 5 bar outlet , with pressure drop +p = 1 bar

Spare parts list

Ref. No.	Coil (without socket)	Ordering no. for
	Voltage	AC 50Hz
1	220	AC11A
	110	AC11B
	48	AC11D
	24	AC11G
	12	- NA -
2	Moving core sub assembly complete consists of 1. moving core subassembly 2. main spring	SSA0411

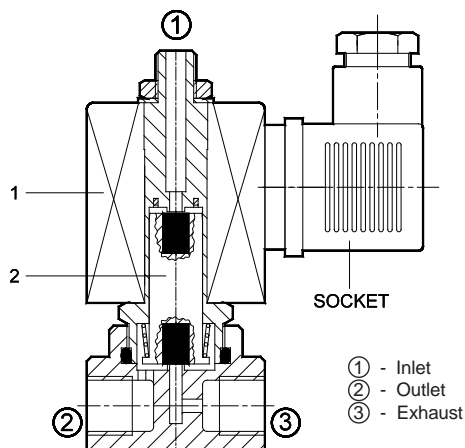
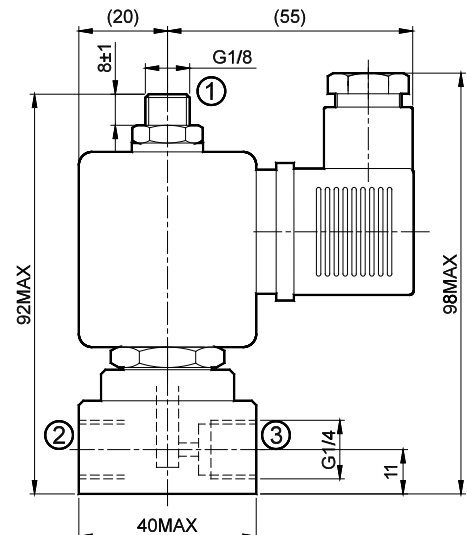
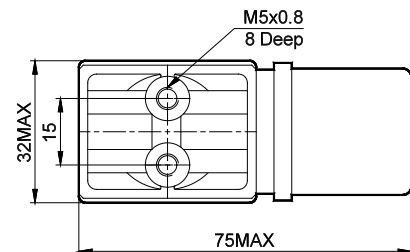

Caution:

A.C coil should not be used on a D.C coil valve, and vice versa.

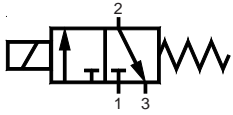

SOLENOID VALVE - G1/4

J Series

Cat No J003 - 04

3 / 2 Direct acting normally closed valve

Features

- Wide range of coil voltages.
- Continuous duty cycle.
- Low temperature of operation
- Noiseless performance
- Coil can be rotated by 360°.

Technical Specifications

Model #	E14613	E14612	E14611
Port size	Inlet, Outlet - G1/4, Exhaust - G1/8		
Ambient Temperature	60°C Max.		
Medium	Filtered compressed air		
Orifice (NW)	2.5	2	1.2
Operating pressure (bar)	0 - 7	0 - 10	0 - 20
Flow rate (lpm) *	180	140	60
Electrical			
Coil width	32 mm		
Voltage (V) ± 10%	AC (50 Hz) 24, 48, 110, 220		DC 12, 24, 48, 110
	Power consumption (Watts)	6	9
Duty cycle	Continuous		
Type of coil protection	IP65		
Class of insulation	Class F		
Materials of construction	Aluminium, Brass, Stainless steel, Nitrile		



For ordering refer page no.3.1.1

* at 6 bar inlet, 5 bar outlet , with pressure drop +p = 1 bar

Spare parts list

Ref. No.	Coil (without socket) Voltage	Ordering no. for	
		AC 50Hz	DC
1	220	AC11A	- NA -
	110	AC11B	DC12Q
	48	AC11D	DC12S
	24	AC11G	DC12W
	12	- NA -	DC15R
2	Moving core sub assembly complete consists of 1. moving core subassembly 2. main spring	SSA0311	SSA0711

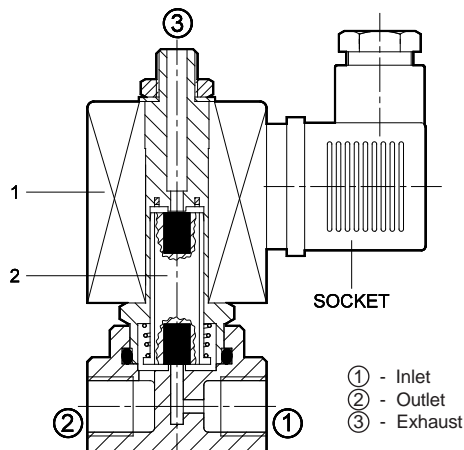
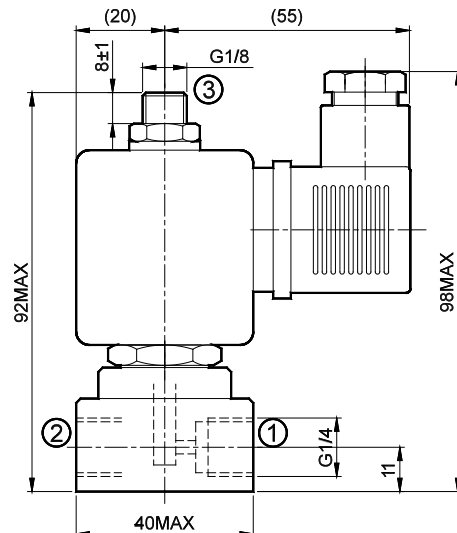
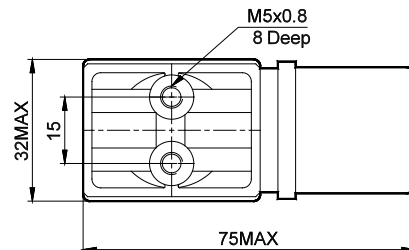

Caution:

A.C coil should not be used on a D.C coil valve, and vice versa.

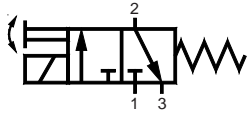

SOLENOID VALVE

J Series

Cat No J004 - 04

3 / 2 Direct acting, normally closed, gang mounting valve

Features

- ❑ Gang mounting type (Manifolds for gang mounting of 1 ,2, 5 & 9.valves are available - for details refer next page)
- ❑ Wide range of coil voltages.
- ❑ Continuous duty cycle.
- ❑ Low temperature of operation
- ❑ Noiseless performance
- ❑ Manual operator (Screw driver type)



Technical Specifications

Model #	E24002		
Port size	Exhaust G1/8		
Ambient Temperature	60°C Max.		
Medium	Filtered compressed air		
Orifice (NW)	2		
Operating pressure range (bar)	0 - 10		
Flow rate (lpm) *	140		
Electrical			
Coil width	32 mm		
Voltage (V) ± 10%	AC (50 Hz)	DC	
	24, 48, 110, 220	12	24, 48, 110
Power consumption (Watts)	6	9	8
Duty cycle	Continuous		
Type of coil protection	IP65		
Class of insulation	Class F		
Materials of construction	Aluminium, Brass, Stainless steel, Nitrile		

For ordering refer page no.3.1.1

* at 6 bar inlet, 5 bar outlet , with pressure drop +p = 1 bar

Spare parts list

Ref. No.	Coil (without socket)	Ordering no. for	
		AC 50Hz	DC
1	220	AC11A	- NA -
	110	AC11B	DC12Q
	48	AC11D	DC12S
	24	AC11G	DC12W
	12	- NA -	DC15R
2	Moving core sub assembly complete consists of 1. moving core subassembly 2. main spring	SSA0311	SSA0711

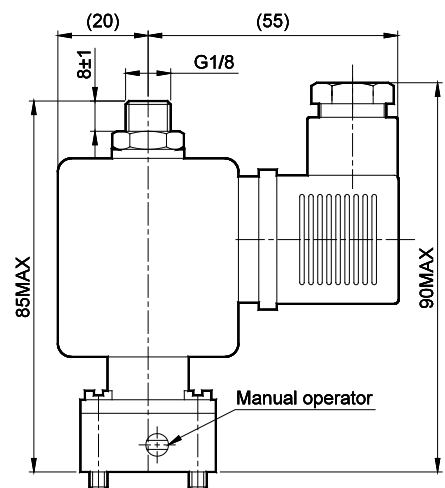
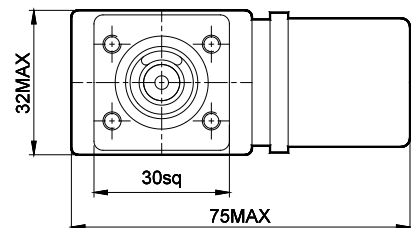
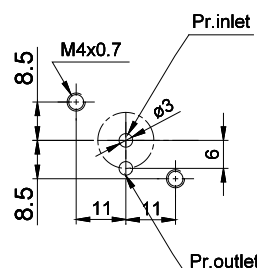
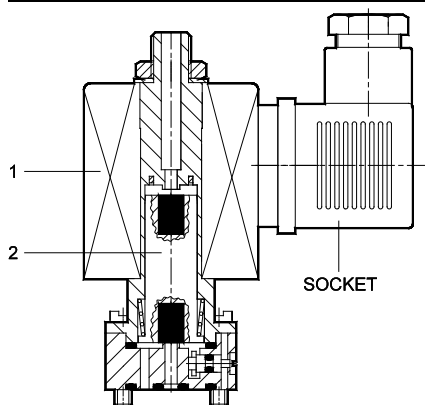

Caution:

A.C coil should not be used on a D.C coil valve, and vice versa.

Manifold for Gang Mounting Valves

Plug type manifold

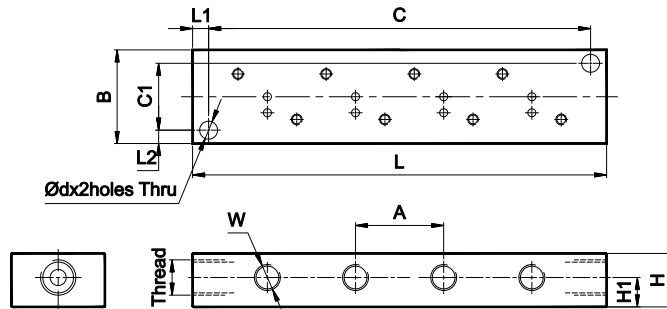

Part Name	Thread	W	B	C	C1	A	Ød	L	L1	L2	H	H1	Ordering no.
Four valves	G1/4	G1/8	35	143	25	33	6.7	155	6	5	20	11	LA3029
Six valves	G1/4	G1/8	35	209	25	33	6.7	221	6	5	20	11	LA3030
Nine valves	G1/4	G1/8	35	308	25	33	6.7	320	6	5	20	11	42312

Connector type manifold

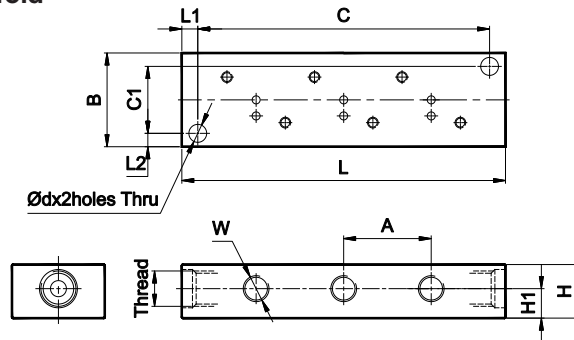

Part Name	Thread	W	B	C	C1	A	Ød	L	L1	L2	H	H1	Ordering no.
One valve	G1/4	G1/8	35	44	25	-	6.7	56	6	5	20	11	42080
Two valves	G1/4	G1/8	35	77	25	33	6.7	89	6	5	20	11	42070
Three valves	G1/4	G1/8	35	110	25	33	6.7	122	6	5	20	11	LA3035
Five valves	G1/4	G1/8	35	176	25	33	6.7	188	6	5	20	11	42069

Connector assembly

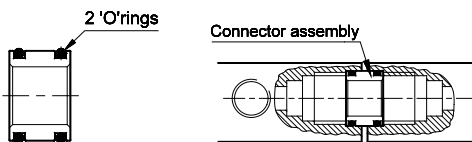

Application:

These connector assemblies can be used to connect two manifolds. For eg., 2 no's of manifolds to Model no. 42080 can be connected together. This is applicable for the connector type manifold only.

Part Name	Ordering no.
Connector assembly	MS001
Cover plate assembly	MS002

Cover plate assembly

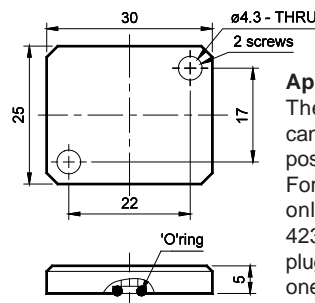

Application:

These cover plate assemblies can be used to plug the unutilised position in a manifold.

For eg., if it is required to mount only 8 valves on manifold no. 42312, the 9th position can be plugged and made dummy using one cover plate assembly.

How to Order

While ordering valve, mention the ordering number given in the corresponding tables.

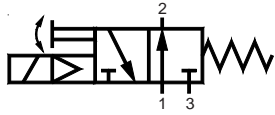

SOLENOID VALVE - G1/4

J Series

Cat No J005 - 05

3 / 2 Pilot operated normally open valve

Features

- ❑ Diaphragm operated poppet seat type.
- ❑ Wide range of coil voltages.
- ❑ Continuous duty cycle.
- ❑ Low temperature of operation
- ❑ Manual operator (Screw driver type)
- ❑ Noiseless performance
- ❑ Good flow characteristics.

Technical Specifications

Model #	EL13615		
Port size	Inlet, Outlet, Exhaust - G1/4		
Ambient Temperature	60°C Max.		
Medium	Filtered compressed air		
Orifice (NW)	6		
Operating pressure range (bar)	2 - 10		
Cv value	0.65		
Flow rate (lpm) *	650		
Electrical			
Coil width	32 mm		
Voltage (V) ± 10%	AC (50 Hz)	DC	
	24, 48, 110, 220	12	24, 48, 110
Power consumption (Watts)	6	9	8
Duty cycle	Continuous		
Type of coil protection	IP65		
Class of insulation	Class F		
Materials of construction	Aluminium, Brass, Stainless steel, Nitrile		

For ordering refer page no.3.1.1

* at 6 bar inlet, 5 bar outlet , with pressure drop +p = 1 bar

Spare parts list

Ref. No.	Coil (without socket)	Ordering no. for		
		Voltage	AC	DC
1		220	AC11A	- NA -
		110	AC11B	DC12Q
		48	AC11D	DC12S
		24	AC11G	DC12W
		12	- NA -	DC15R
2	Moving core sub assembly complete consists of 1. moving core subassembly 2. main spring	SSA0311	SSA0711	
3	Solenoid valve sub assembly complete (without coil) Consists of 1. Solenoid valve sub assembly 2. Screws – 2 no's 3. 'O'rings – 2 no's	E24001-A	E24001-D	
	Seal kit consists of all rubber items for the main valve (4)	SK3611		

Caution:

A. To ensure proper functioning

1. Please ensure that inlet port is connected to tubing of 6 mm ID minimum from the compressor air source.
2. Exhaust should not be restricted.

B. A.C coil should not be used on a D.C coil valve, and vice versa.

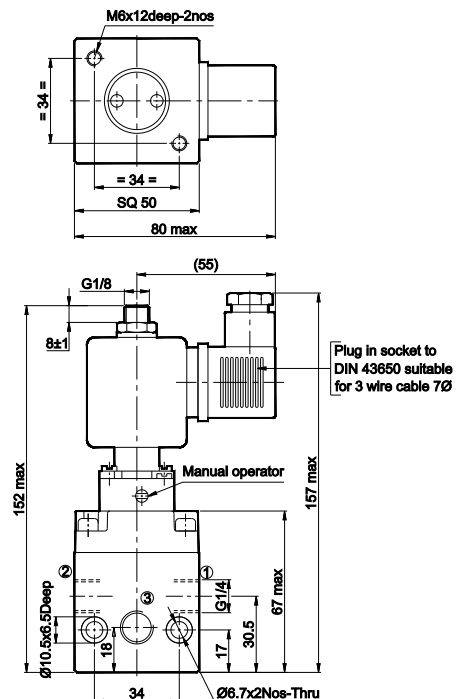

- ① - Inlet
- ② - Outlet
- ③ - Exhaust

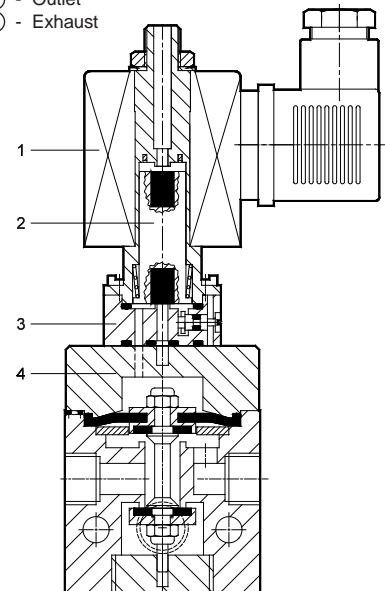

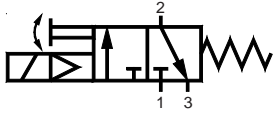

SOLENOID VALVE - G1/4

J Series

Cat No J006 - 05

3 / 2 Pilot operated normally closed valve

Features

- ❑ Diaphragm operated poppet seat type.
- ❑ Wide range of coil voltages.
- ❑ Continuous duty cycle.
- ❑ Low temperature of operation
- ❑ Manual operator (Screw driver type)
- ❑ Noiseless performance
- ❑ Good flow characteristics.



Technical Specifications

Model #	EL14615		
Port size	Inlet, Outlet, Exhaust - G1/4		
Ambient Temperature	60°C Max.		
Medium	Filtered compressed air		
Orifice (NW)	6		
Operating pressure range (bar)	2 – 10		
Cv value	0.65		
Flow rate (lpm) *	650		
Electrical			
Coil width	32 mm		
Voltage (V) ± 10%	AC (50 Hz)	DC	
	24, 48, 110, 220	12	24, 48, 110
Power consumption (Watts)	6	9	8
Duty cycle	Continuous		
Type of coil protection	IP65		
Class of insulation	Class F		
Materials of construction	Aluminium, Brass, Stainless steel, Nitrile		

For ordering refer page no.3.1.1

* at 6 bar inlet, 5 bar outlet , with pressure drop +p = 1 bar

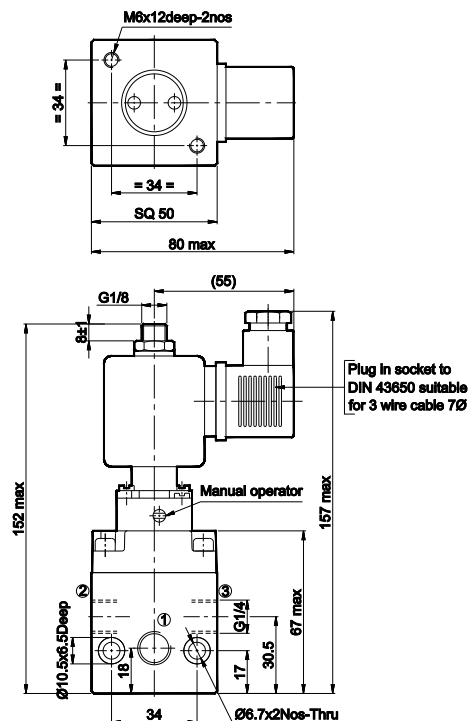

Spare parts list

Ref. No.	Coil (without socket)	Ordering no. for		
		Voltage	AC	DC
1		220	AC11A	- NA -
		110	AC11B	DC12Q
		48	AC11D	DC12S
		24	AC11G	DC12W
		12	- NA -	DC15R
2	Moving core sub assembly complete consists of 1. moving core subassembly 2. main spring	SSA0311	SSA0711	
3	Solenoid valve sub assembly complete (without coil) Consists of 1. Solenoid valve sub assembly 2. Screws – 2 no's 3. O'rings – 2 no's	E24001-A	E24001-D	
	Seal kit consists of all rubber items for the main valve (4)	SK3611		

- ① - Inlet
- ② - Outlet
- ③ - Exhaust

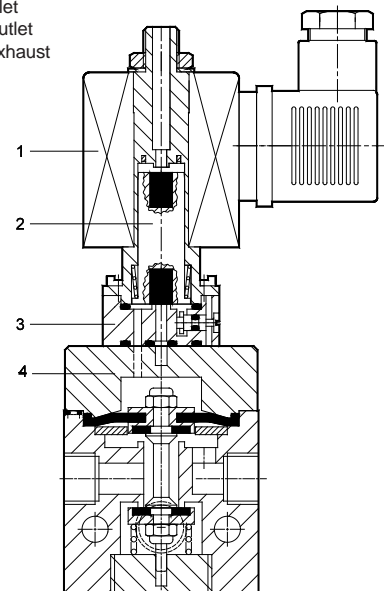

Caution:

A. To ensure proper functioning

1. Please ensure that inlet port is connected to tubing of 6 mm ID minimum from the compressor air source.
2. Exhaust should not be restricted.

B. A.C coil should not be used on a D.C coil valve, and vice versa.

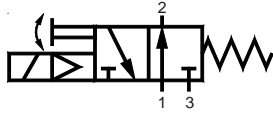

SOLENOID VALVE - G1/2

J Series

Cat No J007 - 05

3 / 2 Pilot operated normally open valve

Features

- ❑ Diaphragm operated poppet seat type.
- ❑ Wide range of coil voltages.
- ❑ Continuous duty cycle.
- ❑ Low temperature of operation
- ❑ Manual operator (Screw driver type)
- ❑ Noiseless performance
- ❑ Good flow characteristics.



Technical Specifications

Model #	EL13637		
Port size	Inlet, Outlet, Exhaust - G1/2		
Ambient Temperature	60°C Max.		
Medium	Filtered compressed air		
Orifice (NW)	12		
Operating pressure range (bar)	2 - 10		
Cv value	3		
Flow rate (lpm) *	3000		
Electrical			
Coil width	32 mm		
Voltage (V) ± 10%	AC (50 Hz)	DC	
	24, 48, 110, 220	12	24, 48, 110
Power consumption (Watts)	6	9	8
Duty cycle	Continuous		
Type of coil protection	IP65		
Class of insulation	Class F		
Materials of construction	Aluminium, Brass, Stainless steel, Nitrile		

For ordering refer page no.3.1.1

* at 6 bar inlet, 5 bar outlet , with pressure drop +p = 1 bar

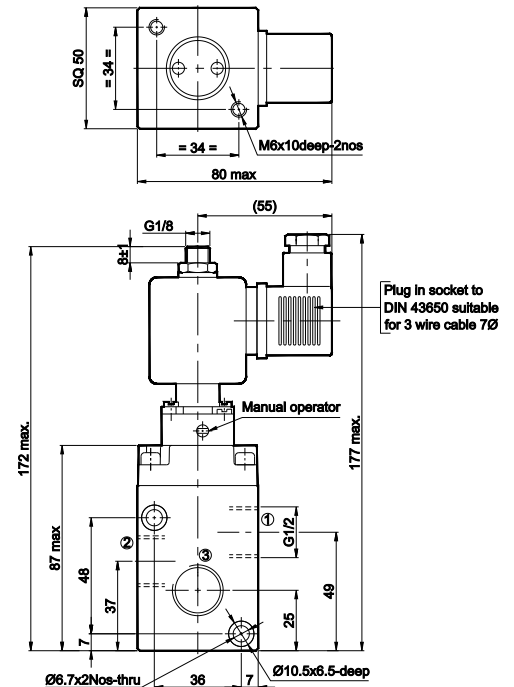

Spare parts list

Ref. No.	Coil (without socket)	Ordering no. for	
	Voltage	AC	DC
1	220	AC11A	- NA -
	110	AC11B	DC12Q
	48	AC11D	DC12S
	24	AC11G	DC12W
	12	- NA -	DC15R
2	Moving core sub assembly complete consists of 1. moving core subassembly 2. main spring	SSA0311	SSA0711
3	Solenoid valve sub assembly complete (without coil) Consists of 1. Solenoid valve sub assembly 2. Screws – 2 no's 3. 'O'rings – 2 no's	E24001-A	E24001-D
	Seal kit consists of all rubber items for the main valve (4)	SK3631	

- ① - Inlet
- ② - Outlet
- ③ - Exhaust

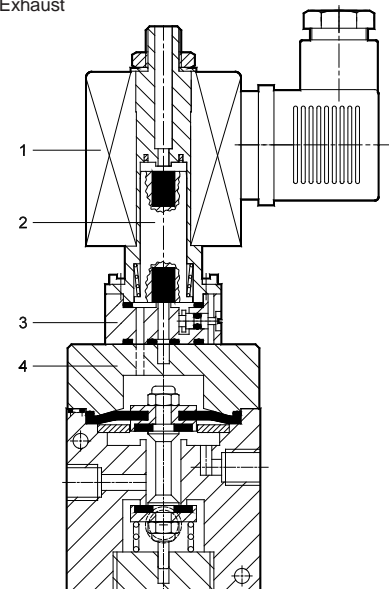

Caution:

A. To ensure proper functioning

1. Please ensure that inlet port is connected to tubing of 10 mm ID minimum from the compressor air source.
2. Exhaust should not be restricted.

B. A.C coil should not be used on a D.C coil valve, and vice versa.

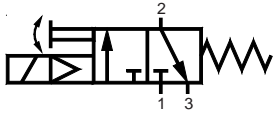

SOLENOID VALVE - G1/2

J Series

Cat No J008 - 05

3 / 2 Pilot operated normally closed valve

Features

- ❑ Diaphragm operated poppet seat type.
- ❑ Wide range of coil voltages.
- ❑ Continuous duty cycle.
- ❑ Low temperature of operation
- ❑ Manual operator (Screw driver type)
- ❑ Noiseless performance
- ❑ Good flow characteristics.



Technical Specifications

Model #	EL14637		
Port size	Inlet, Outlet, Exhaust - G1/2		
Ambient Temperature	60°C Max.		
Medium	Filtered compressed air		
Orifice (NW)	12		
Operating pressure range (bar)	2 - 10		
Cv value	3		
Flow rate (lpm) *	3000		
Electrical			
Coil width	32 mm		
Voltage (V) ± 10%	AC (50 Hz)	DC	
	24, 48, 110, 220	12	24, 48, 110
Power consumption (Watts)	6	9	8
Duty cycle	Continuous		
Type of coil protection	IP65		
Class of insulation	Class F		
Materials of construction	Aluminium, Brass, Stainless steel, Nitrile		

For ordering refer page no.3.1.1

* at 6 bar inlet, 5 bar outlet , with pressure drop +p = 1 bar

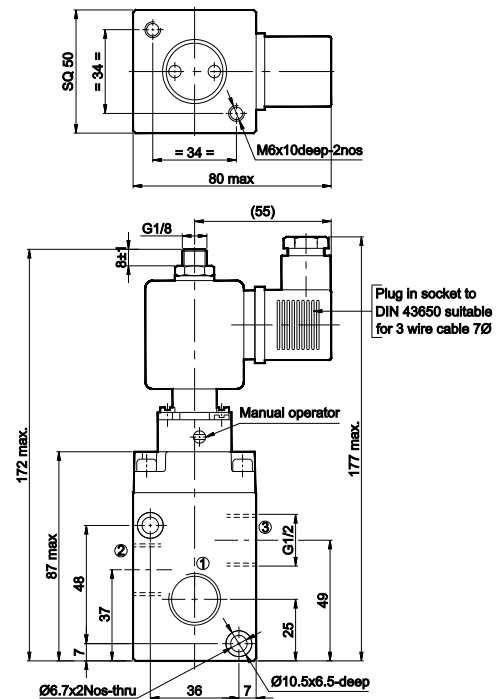

- ① - Inlet
- ② - Outlet
- ③ - Exhaust

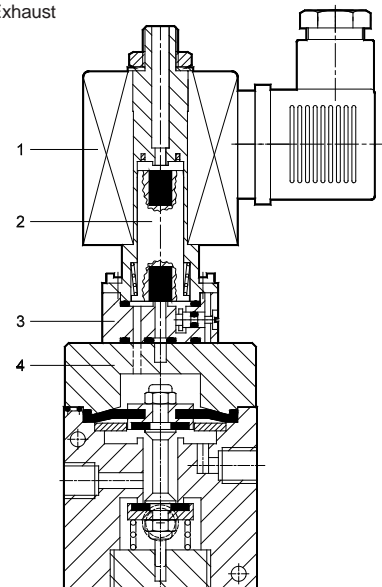

Spare parts list

Ref. No.	Coil (without socket)	Ordering no. for	
		AC	DC
1	220	AC11A	- NA -
	110	AC11B	DC12Q
	48	AC11D	DC12S
	24	AC11G	DC12W
	12	- NA -	DC15R
2	Moving core sub assembly complete consists of 1. moving core subassembly 2. main spring	SSA0311	SSA0711
3	Solenoid valve sub assembly complete (without coil) Consists of 1. Solenoid valve sub assembly 2. Screws – 2 no's 3. O'rings – 2 no's	E24001-A	E24001-D
	Seal kit consists of all rubber items for the main valve (4)	SK3631	

Caution:

A. To ensure proper functioning

1. Please ensure that inlet port is connected to tubing of 10 mm ID minimum from the compressor air source.
2. Exhaust should not be restricted.

B. A.C coil should not be used on a D.C coil valve, and vice versa.



SOLENOID VALVE - G1/4

J Series

Cat No J009 - 05

5 / 2 Single solenoid pilot operated valve

Features

- ❑ Diaphragm operated poppet seat type.
- ❑ Wide range of coil voltages.
- ❑ Continuous duty cycle.
- ❑ Low temperature of operation
- ❑ Manual operator (Screw driver type)
- ❑ Noiseless performance
- ❑ Good flow characteristics.



Technical Specifications

Model #	EL15615		
Port size	Inlet, Outlet, Exhaust - G1/4		
Ambient Temperature	60°C Max.		
Medium	Filtered compressed air		
Orifice (NW)	6		
Operating pressure range (bar)	2 - 10		
Cv value	0.65		
Flow rate (lpm) *	650		
Electrical			
Coil width	32 mm		
Voltage (V) ± 10%	AC (50 Hz) 24, 48, 110, 220	12	DC 24, 48, 110
Power consumption (Watts)	6	9	8
Duty cycle	Continuous		
Type of coil protection	IP65		
Class of insulation	Class F		
Materials of construction	Aluminium, Brass, Stainless steel, Nitrile		

For ordering refer page no.3.1.1

* at 6 bar inlet, 5 bar outlet , with pressure drop +p = 1 bar

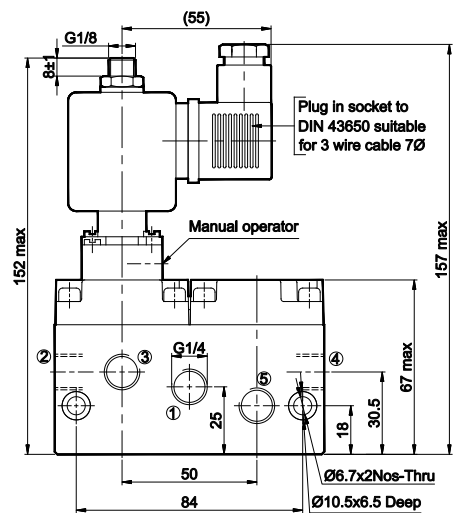
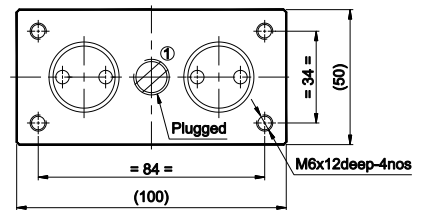

- ① - Inlet - 2 nos.
- ②, ④ - Outlet
- ③, ⑤ - Exhaust

Spare parts list

Ref. No.	Coil (without socket)	Ordering no. for	
	Voltage	AC	DC
1	220	AC11A	- NA -
	110	AC11B	DC12Q
	48	AC11D	DC12S
	24	AC11G	DC12W
	12	- NA -	DC15R
2	Moving core sub assembly complete consists of 1. moving core subassembly 2. main spring	SSA0311	SSA0711
3	Solenoid valve sub assembly complete (without coil) Consists of 1. Solenoid valve sub assembly 2. Screws – 2 no's 3. 'O' rings – 2 no's	E24001-A	E24001-D
	Seal kit consists of all rubber items for the main valve (4)	SK5611	

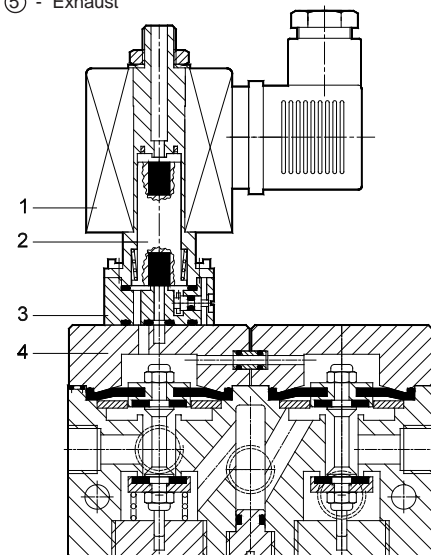

Caution:

A. To ensure proper functioning

1. Please ensure that inlet port is connected to tubing of 6 mm ID minimum from the compressor air source.
2. Exhaust should not be restricted.

B. A.C coil should not be used on a D.C coil valve, and vice versa.

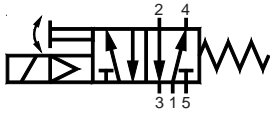

SOLENOID VALVE - G1/2

J Series

Cat No J010 - 05

5 / 2 Single solenoid pilot operated valve

Features

- ❑ Diaphragm operated poppet seat type.
- ❑ Wide range of coil voltages.
- ❑ Continuous duty cycle.
- ❑ Low temperature of operation
- ❑ Manual operator (Screw driver type)
- ❑ Noiseless performance
- ❑ Good flow characteristics.



Technical Specifications

Model #	EL15637		
Port size	Inlet, Outlet, Exhaust - G1/2		
Ambient Temperature	60°C Max.		
Medium	Filtered compressed air		
Orifice (NW)	12		
Operating pressure (bar)	2 - 10		
Cv value	3		
Flow rate (lpm) *	3000		
Electrical			
Coil width	32 mm		
Voltage (V) ± 10%	AC (50 Hz) 24, 48, 110, 220	12	DC 24, 48, 110
Power consumption (Watts)	6	9	8
Duty cycle	Continuous		
Type of coil protection	IP65		
Class of insulation	Class F		
Materials of construction	Aluminium, Brass, Stainless steel, Nitrile		

For ordering refer page no.3.1.1

* at 6 bar inlet, 5 bar outlet , with pressure drop +p = 1 bar

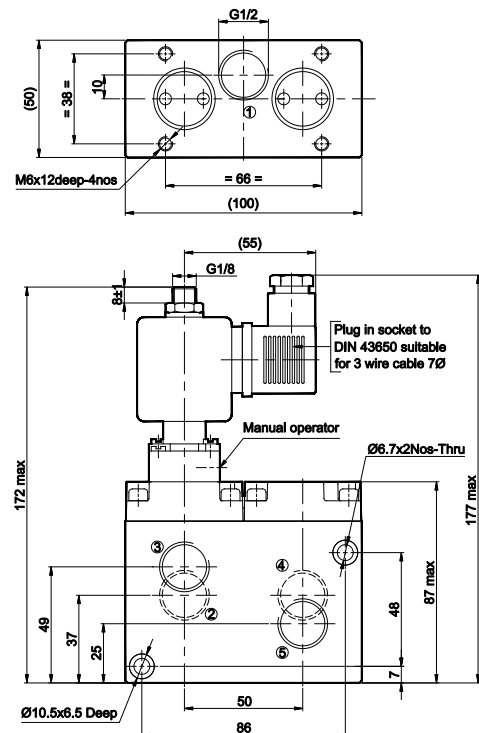

- ① - Inlet
- ②, ④ - Outlet
- ③, ⑤ - Exhaust

Spare parts list

Ref. No.	Coil (without socket)	Ordering no. for	
		AC	DC
1	220	AC11A	- NA -
	110	AC11B	DC12Q
	48	AC11D	DC12S
	24	AC11G	DC12W
	12	- NA -	DC15R
2	Moving core sub assembly complete consists of 1. moving core subassembly 2. main spring	SSA0311	SSA0711
3	Solenoid valve sub assembly complete (without coil) Consists of 1. Solenoid valve sub assembly 2. Screws – 2 no's 3. O'rings – 2 no's	E24001-A	E24001-D
	Seal kit consists of all rubber items for the main valve (4)	SK5631	

Caution:

A. To ensure proper functioning

1. Please ensure that inlet port is connected to tubing of 10 mm ID minimum from the compressor air source.
2. Exhaust should not be restricted.

B. A.C coil should not be used on a D.C coil valve, and vice versa.

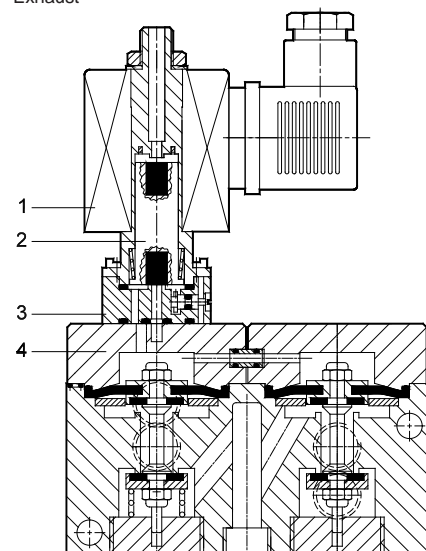

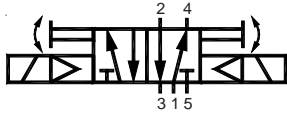

SOLENOID VALVE - G1/4

J Series

Cat No J011 - 05

5 / 2 Double solenoid pilot operated valve

Features

- ❑ Diaphragm operated poppet seat type.
- ❑ Wide range of coil voltages.
- ❑ Continuous duty cycle.
- ❑ Low temperature of operation
- ❑ Manual operator (Screw driver type)
- ❑ Noiseless performance
- ❑ Good flow characteristics.



Technical Specifications

Model #	EL25615		
Port size	Inlet, Outlet, Exhaust - G1/4		
Ambient Temperature	60°C Max.		
Medium	Filtered, Lubricated compressed air		
Orifice (NW)	6		
Operating pressure range (bar)	2 – 10		
Cv value	0.65		
Flow rate (lpm) *	650		
Electrical			
Coil width	32 mm		
Voltage (V) ± 10%	AC (50 Hz) 24, 48, 110, 220	DC 12 24, 48, 110	
Power consumption (Watts)	6	9	8
Duty cycle	Continuous		
Type of coil protection	IP65		
Class of insulation	Class F		
Materials of construction	Aluminium, Brass, Stainless steel, Nitrile		

For ordering refer page no.3.1.1

* at 6 bar inlet, 5 bar outlet , with pressure drop +p = 1 bar

Spare parts list

Ref. No.	Coil (without socket)	Ordering no. for	
		AC	DC
1	220	AC11A	- NA -
	110	AC11B	DC12Q
	48	AC11D	DC12S
	24	AC11G	DC12W
	12	- NA -	DC15R
2	Moving core sub assembly complete consists of 1. moving core subassembly 2. main spring	SSA0311	SSA0711
3	Solenoid valve sub assembly complete (without coil) Consists of 1. Solenoid valve sub assembly 2. Screws – 2 no's 3. 'O'rings – 2 no's	E22001-A	E22001-D
	Seal kit consists of all rubber items for the main valve (4)	SK5612	

Caution:

A. To ensure proper functioning

1. Please ensure that inlet port is connected to tubing of 6 mm ID minimum from the compressor air source.
2. Exhaust should not be restricted.

B. Stay put function

When the valve is in operation, it will be in stay out condition even if the power fails, provided the inlet pressure remains above 2 bar.

C. A.C coil should not be used on a D.C coil valve, and vice versa.

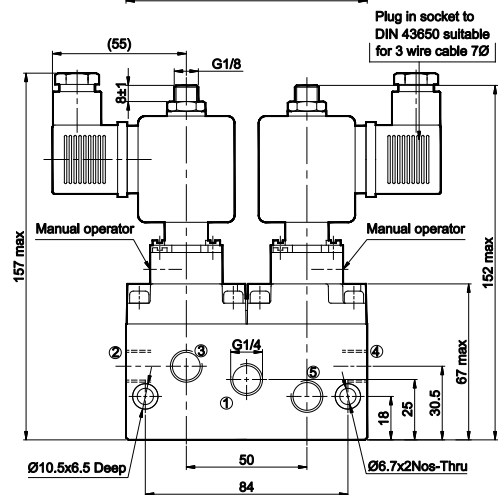
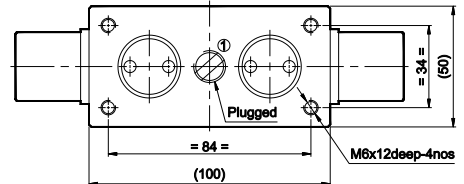

- ① - Inlet - 2 nos.
- ②, ④ - Outlet
- ③, ⑤ - Exhaust

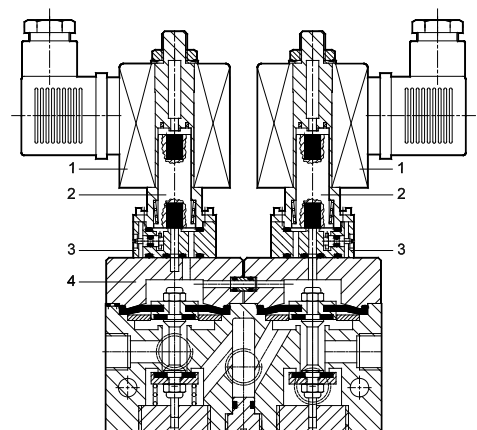

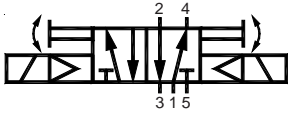

SOLENOID VALVE - G1/2

J Series

Cat No J012 - 05

5 / 2 Double solenoid pilot operated valve

Features

- ❑ Diaphragm operated poppet seat type.
- ❑ Wide range of coil voltages.
- ❑ Continuous duty cycle.
- ❑ Low temperature of operation
- ❑ Manual operator (Screw driver type)
- ❑ Noiseless performance
- ❑ Good flow characteristics.



Technical Specifications

Model #	EL25637		
Port size	Inlet, Outlet, Exhaust - G1/2		
Ambient Temperature	60°C Max.		
Medium	Filtered , Lubricated compressed air		
Orifice (NW)	12		
Operating pressure range (bar)	2 - 10		
Cv value	3		
Flow rate (lpm) *	3000		
Electrical			
Coil width	32 mm		
Voltage (V) ± 10%	AC (50 Hz) 24, 48, 110, 220	12	DC 24, 48, 110
Power consumption (Watts)	6	9	8
Duty cycle	Continuous		
Type of coil protection	IP65		
Class of insulation	Class F		
Materials of construction	Aluminium, Brass, Stainless steel, Nitrile		

For ordering refer page no.3.1.1

* at 6 bar inlet, 5 bar outlet , with pressure drop +p = 1 bar

Spare parts list

Ref. No.	Coil (without socket)	Ordering no. for	
		AC	DC
1	220	AC11A	- NA -
	110	AC11B	DC12Q
	48	AC11D	DC12S
	24	AC11G	DC12W
	12	- NA -	DC15R
2	Moving core sub assembly complete consists of 1. moving core subassembly 2. main spring	SSA0311	SSA0711
3	Solenoid valve sub assembly complete (without coil) Consists of 1. Solenoid valve sub assembly 2. Screws – 2 no's 3. 'O' rings – 2 no's	E22001-A	E22001-D
	Seal kit consists of all rubber items for the main valve (4)	SK5632	

Caution:

A. To ensure proper functioning

1. Please ensure that inlet port is connected to tubing of 10 mm ID minimum from the compressor air source.
2. Exhaust should not be restricted.

B. Stay put function

When the valve is in operation, it will be in stay out condition even if the power fails, provided the inlet pressure remains above 2 bar.

C. A.C coil should not be used on a D.C coil valve, and vice versa.

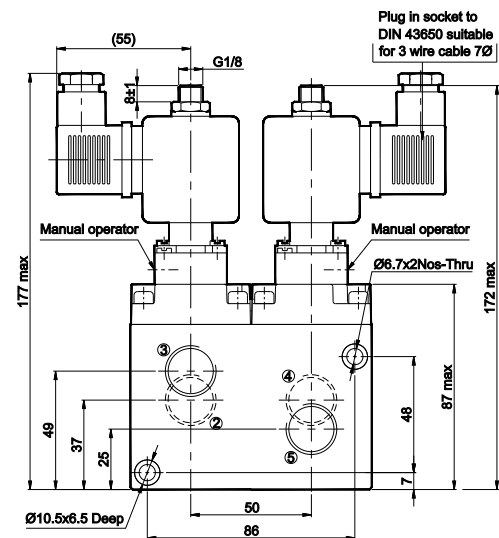
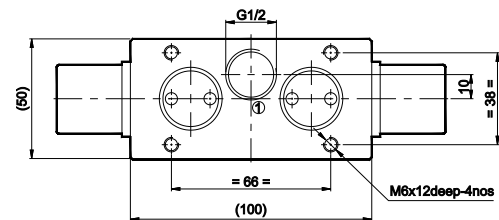

- ① - Inlet
- ②, ④ - Outlet
- ③, ⑤ - Exhaust

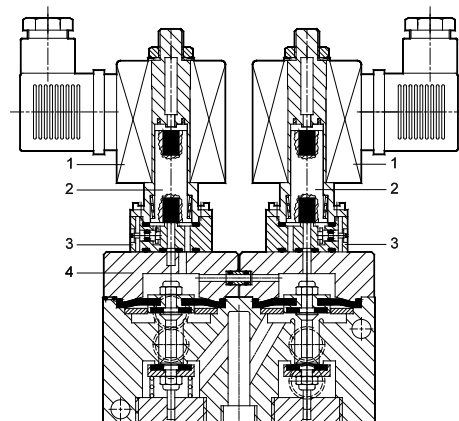

SOLENOID VALVE

J Series

How to order

1. Solenoid valve + “ Connectors without LED ”

While ordering Solenoid operated valves, please mention the suffix given below along with the model number to indicate the required voltage

A	220V AC	Q	110V D C
B	110V AC	S	48V D C
D	48V AC	W	24V D C
G	24V AC	R	12V D C

Example

- The ordering no. for 3 / 2 pilot operated NC valve with 24V D.C coil is **EL14615-W**
- The ordering no. for 3 / 2 pilot operated NC valve with 24V D.C coil with Moulded cable is **EL14615-W1**

2. Solenoid valve + “ Connectors with LED ”

While ordering Solenoid operated valves with LED connectors, given below in the corresponding tables.

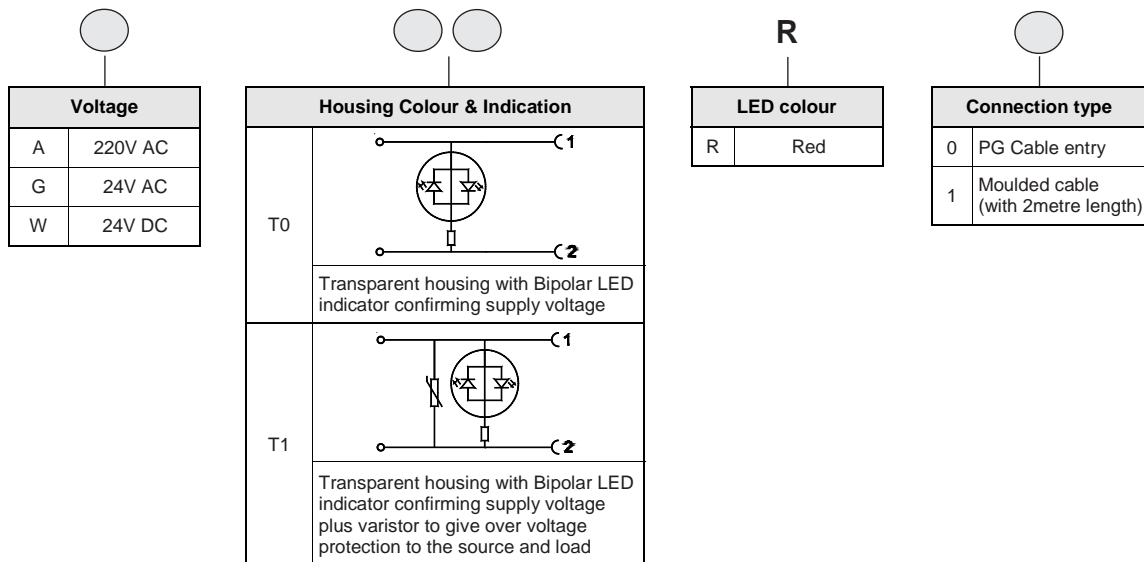

Example

The ordering no. for 3 / 2 pilot operated NC valve with 24V D.C, connectors with LED of Transparent colour housing with Bipolar LED and varistor with moulded cable : **EL14615-WT1R1**

Example

The ordering no. for 3 / 2 pilot operated NC valve with 24V D.C coil is **EL14615W** with screw type manual adjuster (Standard model)

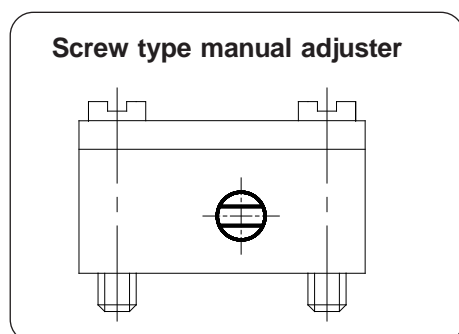

Knob type manual adjuster

The ordering no. for 3 / 2 pilot operated NC valve with 24V D.C coil is **EL14615W - K** with knob type manual adjuster

